

E T C A R C H I T E C T U R A L

AR 50 Interior Wash

Irideon™ Automated Luminaires

User Guide



IRIDEON™
Building With Light

Electronic Theatre Controls, Inc.

Irideon®
AR50™ Interior Wash
Luminaire

User Guide

Copyright

Copyright © 1997, 1998, 1999, 2000, Electronic Theatre Controls, Inc. All Rights Reserved.

Portions of the software described in this document copyright © Microsoft Corporation. All rights reserved.

Information in this document is subject to change without notice. The software described in this document is furnished under a license agreement or nondisclosure agreement. The software may be used or copied only in accordance with the terms of those agreements. No part of this publication may be reproduced, stored in a retrieval system, or transmitted in any form or any means electronic or mechanical, including photocopying and recording for any purpose other than the purchaser's use without the written permission of ETC, Inc.

Electronic Theatre Controls, Incorporated

3030 Laura Lane

Middleton, WI 53562

U.S.A.

Trademarks

Irideon® is a registered trademark, and AR5™, AR6™, AR7™, AR50™, Composer™, and DMX Interpreter™ are trademarks of ETC, Inc.

Intel® is a registered trademark and Pentium is a trademark of Intel Corporation.

Microsoft® and MS-DOS® are registered trademarks, and Windows is a trademark of Microsoft Corporation.

All other registered and unregistered trademarks are the sole property of their respective owners.

ETC Document No. 7092M1007

Printed in the United States of America

Software License Agreement

Software Copyright © 1997, 1998, 1999, 2000, Electronic Theatre Controls, Inc. All Rights Reserved.

Before using the equipment, please carefully read the software license provisions below. If you do not agree with the provisions, promptly return the equipment to ETC, Inc. and your money will be refunded.

(a) Purchaser is granted a personal, non-exclusive license to use the software solely to operate the equipment for its intended purpose in a single, permanent installation at the Purchaser's place of use. The Software License continues until Purchaser ceases to use the equipment or transfers the equipment to another party, at which point the license shall be automatically transferred to the new owner, subject to the terms of this license.

(b) Purchaser is authorized to execute the code embodied in the software to enable the equipment to perform according to specifications.

(c) Purchaser agrees that it will not use or copy the software, copies of the software, or any code in the software except as expressly authorized in this License and will not modify, merge, disassemble or decompile the software copies thereof, or any code in the software, nor remove any notices or license terms from the equipment or documentation. Information necessary to achieve interoperability of the equipment with other programs is available from ETC, Inc. on request.

(d) Upon the resale of the equipment, the Software License is automatically transferred to the subsequent purchaser, provided the subsequent purchaser agrees to accept the terms of the Software License. Purchaser agrees that it will not sublicense, rent, or assign the software.

(e) All additional software supplied in the form of updates or incorporated in replacement IRIDEON® hardware shall be subject to the terms of the Software License.

(This page intentionally blank)

Contents

Chapter 1. Introduction	1-1
1.1 Scope	1-2
1.2 Related Documents	1-2
1.3 Maintenance	1-2
1.4 Recommended Safety Practices	1-2
1.5 Manual Organization	1-2
1.6 Technical Assistance	1-2
Chapter 2. Description	2-2
2.1 Basic Features and Capabilities	2-2
2.1.1 Intensity	2-3
2.1.2 Focus	2-4
2.1.3 Color	2-4
2.1.4 Beam	2-7
2.1.5 Timing	2-8
2.1.6 Pan / Tilt Positioning	2-8
2.1.7 Color Changing	2-8
2.1.8 Light Distribution	2-8
2.2 Configurations	2-9
2.2.1 System Configuration	2-9
2.2.1.1 Composer Lite Control System	2-9
2.2.2 Unit Configuration	2-12
Chapter 3. Installation	3-1
3.1 Site Preparation	3-2
3.2 Input Power and Control Cabling	3-3
3.2.1 AC Power Input	3-3
3.2.2 Data Wiring	3-3
3.3 Luminaire Installation Procedure	3-4
3.3.1 Unpacking	3-4
3.3.2 Mounting	3-5
3.4 Fixture Address	3-10
3.5 Power Up	3-11
Chapter 4. Test	4-1
4.1 Self Test	4-3
4.2 System Test	4-5
Chapter 5. Troubleshooting	5-1
Chapter 6. Maintenance	6-1
6.1 Lamp Replacement	6-3
6.2 Replacement of CPU PCB	6-5
6.3 Upper Enclosure Replacement Procedures	6-7
6.3.1 Removal and Replacement of Ballast and Low Voltage Power Supply	6-7

(This page intentionally blank)

Chapter 1 - Introduction

This chapter contains the following sections:

- 1.1 Scope
- 1.2 Related Documents
- 1.3 Maintenance
- 1.4 Recommended Safety Practices
- 1.5 Manual Organization
- 1.6 Technical Assistance

1.1 Scope

This manual describes installation and operation procedures for the **IRIDEON® AR50™** luminaire and is intended for those responsible with initial mounting and cabling of the luminaires as well as on-going operation.

1.2 Related Documents

Composer™ Owner's Manual (7090M1003): For installation of **Composer** control systems.

IRIDEON® Composer™ and **Composer Lite™** PC Software User's Guide: For programming and operation of the **Composer** control systems.

AR50 Service Manual (7092M1004): For technical repair of **AR50™** Luminaires.

1.3 Maintenance

This manual contains a troubleshooting guide to aid in the identification of failures discovered during initial installation or daily use and for replacement of user replaceable subassemblies. There are a limited number of user replaceable parts and sub-assemblies in the luminaire.

They are:

Part Description	Part Number
CPU (Central Processing Unit) Circuit Board	7092B5008
Low Voltage Power Supply	PS159
Fan	B124
Ignitor	L1013
Ballast	PS163
Bulb 50 watt	RT168

1.4 Recommended Safety Practices

WARNING: Do not install this equipment with power applied. Ensure incoming power is disconnected prior to installation or maintenance of this equipment.

CAUTION: Bulb may be extremely hot.

1.5 Manual Organization

This manual is divided into six chapters. Chapter 1 contains a brief description of the luminaire, safety precautions, related documentation and what to do about service. Chapter 2 describes the luminaire in terms of its capabilities and possible configurations. Chapter 3 and Chapter 4 discuss installation of the various configurations and how to verify the luminaire is operating properly. Chapter 5 and Chapter 6 are provided to aid in basic troubleshooting and the removal/installation of user replaceable subassemblies.

1.6 Technical Assistance

For technical questions regarding proper installation and troubleshooting of the **IRIDEON® AR50™** Interior Wash Luminaire, please contact your local **ETC** products distributor or call ETC Technical Support in the United States at: 1-608-831-4116 or 1-800-688-4116 (FAX: 1-608-836-1736) or Email at service@etcconnect.com.

Chapter 2 - Description

This chapter contains the following sections:

2.1 Basic Features and Capabilities

2.2 Configurations

2.1 Basic Features and Capabilities

The **IRIDEON® AR50™** interior wash luminaire represents the state-of-the-art in specialized indoor floodlighting. The luminaire features a patented, computer-controlled, dichroic color-changing mechanism, optional diffuser or douser mechanism, interchangeable lenses and robotic pan and tilt. The convection-cooled, lightweight composite housing is designed for use anywhere indoor floodlighting requirements exist.

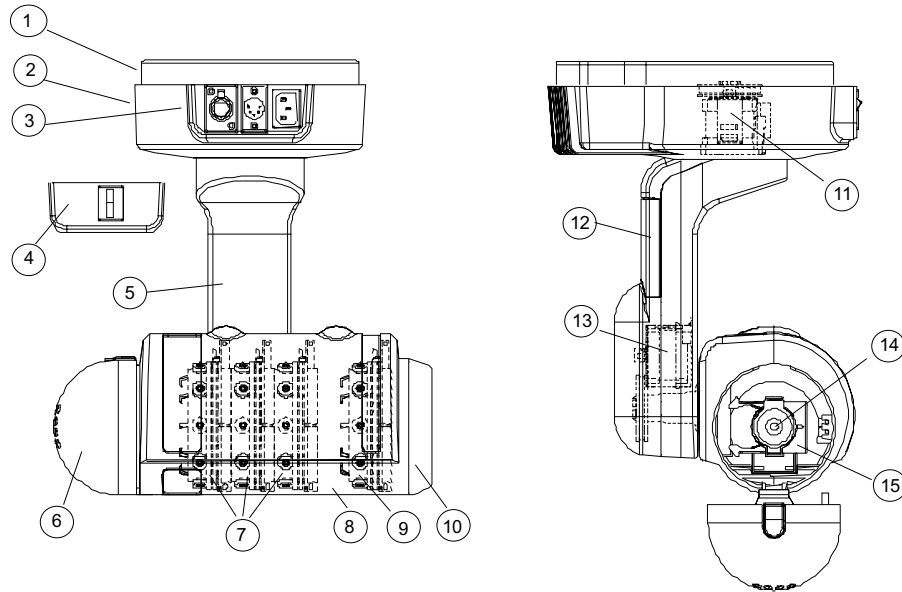

- | | |
|---|--|
| 1. Mounting Plate | 9. Diffuser/Douser Mechanism |
| 2. Upper Enclosure | 10. Front Ring with Lens |
| 3. I/O (Input/Output) Panel Connectorized mount version | 11. Pan Motor |
| 4. I/O (Input/Output) Panel Top Entry mount version | 12. Yoke Cover Door (Fixture Address Access) |
| 5. Yoke Arm | 13. Tilt Motor |
| 6. Rear enclosure assembly | 14. Bulb |
| 7. Color Changing Mechanisms | 15. Bulb Clip |
| 8. Head | |

The **IRIDEON AR50** luminaire can be controlled by the **IRIDEON Composer** and **Composer Lite™** control system or **IRIDEON DMX Interpreter**.

The **IRIDEON AR50** luminaire is an architectural lighting instrument capable of automated color crossfades across the color spectrum and smooth motorized movement (360° pan rotation and 270° tilt). The luminaire is programmable from a personal computer (PC) and controlled by a PC, Master Control Processor with or without remote stations, or DMX Interpreter. The Composer Lite software package allows you to program your system with a PC and then remove the PC for simple stand alone operations. The Luminaires receive data supplied over a single cable to control not only color and direction, but intensity and transition times between lighting effects.

The **IRIDEON AR50** luminaire performs five functions: *intensity*, *focus*, *color*, *beam* and *timing*. A brief description of these five functions follows:

2.1.1 Intensity

The *intensity* function controls the luminaire's level of illumination. The arc bulb always illuminates at full brightness, therefore the intensity level must be controlled by how much of the light is allowed to exit the luminaire. This is accomplished using a radial filter mechanism with black panels replacing the color filters. These panels are tilted at different angles to regulate the amount of light allowed to pass. When chosen as an order option, the douser (dimmer) is generally located in the front of the luminaire between the color changing mechanisms and the front lens. In the **AR50** luminaire, *intensity* can be controlled manually, or stored in the preset and activated when the command is executed.

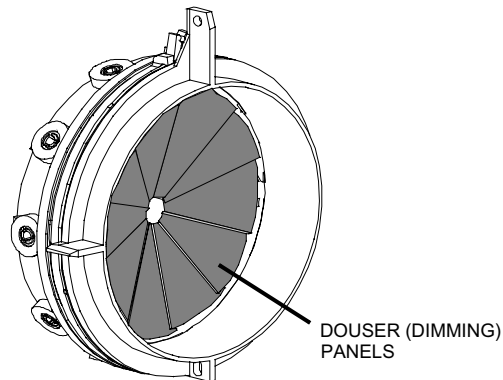

2.1.2 Focus

The *focus* function is the luminaire's ability to pan and tilt. **Pan** refers to the luminaires' ability to move its head 360° about an axis perpendicular to the upper enclosure mounting surface.

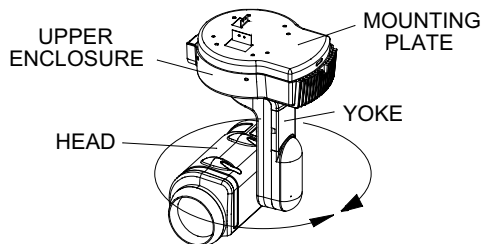

The luminaire's head can be angled 270° about an axis perpendicular to the yoke arm. This movement is referred to as **tilt**.

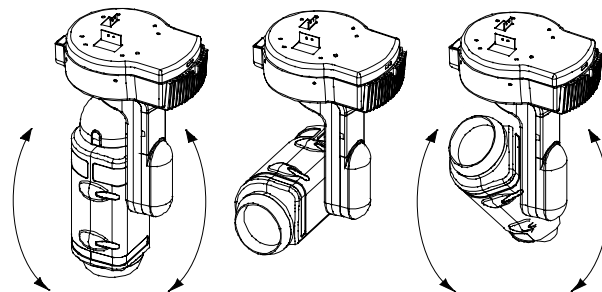

In the **AR50** luminaire, *focus* can be controlled manually or stored in the preset and activated when the command is executed.

2.1.3 Color

The *color* function controls the color changing mechanisms, also known as color filter bulkheads, opening or closing in the path of the light beam allowing a smooth transition from one color to another. When one or more color changing mechanisms are placed in closed or partial closed positions, the beam of light is filtered by the panels of the mechanisms and the exiting light color is effected. A broad color spectrum is achievable by combining and varying the angle of each color mechanism

All three color changing mechanisms are open in the illustration below, therefore the beam of light is unaffected by them and the exiting beam color is open white.

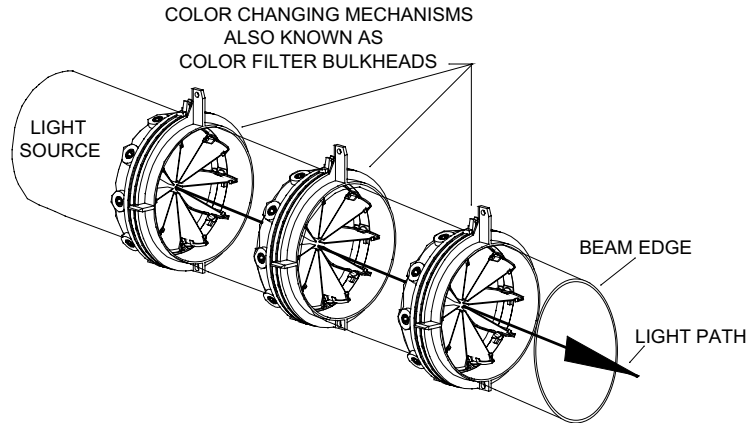

Two of the three color mechanisms in the example below are in their full closed position contributing to the final beam color exiting the luminaire.

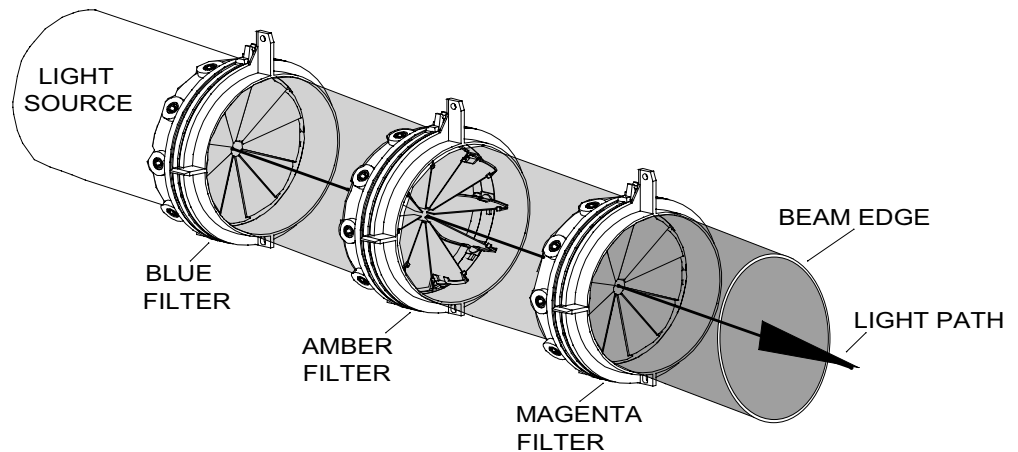

When programming a luminaire color from a **Composer** control system or a remote DMX-512 console, use the following table of values and channel percentages to create colors. Adjust color values or DMX channel percentages according to the chart to create the desired color. An **Irideon** color (IC) code has been given for each of the listed colors. Those with an “X” in the left-hand column have been pre-established in the **Composer** and **Composer Lite** Preset Editor and may be selected by clicking on that named color.

	Color	IC	Blue Filter		Amber Filter		Magenta Filter	
			Value	%	Value	%	Value	%
X	White	100	0	0	0	0	0	0
	Light Bastard Amber	105	0	0	45	18	45	18
	Dark Bastard Amber	115	0	0	90	35	80	31
X	Deepest Salmon	139	0	0	115	45	135	53
	Darkest Red	141	0	0	255	100	255	100
X	Medium Red	145	0	0	235	92	235	92
	Light Red	150	0	0	200	78	215	84
	Light Salmon	136	0	0	90	35	105	41
X	Medium Salmon	138	0	0	110	43	120	47
	Dark Salmon	140	0	0	130	51	150	59
	Dark Orange	161	0	0	190	75	200	78
X	Orange	171	0	0	190	75	185	73
	Light Orange	181	0	0	165	65	175	69
	Amber	191	0	0	155	61	160	63
X	Light Amber	195	0	0	150	59	145	57
	Pale Straw	201	0	0	110	43	0	0
	Straw	210	0	0	130	51	0	0
	Light Yellow	215	0	0	160	63	0	0
	Yellow	225	0	0	210	82	0	0
	Dark Yellow	230	0	0	240	94	0	0
	Light Yellow Green	251	60	24	175	69	0	0
X	Med. Yellow Green	255	75	29	150	59	0	0
	Bright Yellow Green	258	255	100	145	57	0	0
X	Primary Green	265	200	78	145	57	0	0
	Kelly Green	270	175	69	150	59	0	0
	Dark Green	272	135	53	150	59	0	0
	Peacock Green	275	155	61	115	45	0	0
	Dark Peacock Green	278	135	53	115	45	0	0
X	Cyan	291	135	53	90	35	0	0
	Dark Cyan	293	150	59	50	20	0	0

	Color	IC	Blue Filter		Amber Filter		Magenta Filter	
			Value	%	Value	%	Value	%
	Bright Steel Blue	301	255	100	0	0	0	0
	Medium Steel Blue	310	180	71	0	0	0	0
	Dark Steel Blue	325	165	65	0	0	0	0
	Light Blue	335	150	59	0	0	75	29
X	Medium Blue	351	150	59	0	0	115	45
	Dark Blue	375	150	59	0	0	255	100
	Light U.V.	381	150	59	0	0	170	67
	Dark U.V.	399	150	59	0	0	150	59
	Dark Lavender	411	150	59	0	0	150	59
X	Medium Lavender	421	200	78	0	0	150	59
	Light lavender	430	230	90	0	0	150	59
	Pale Lavender	440	255	100	0	0	125	49
X	Dark Pale Lavender	435	255	100	0	0	140	55
	No Color Lavender	450	255	100	0	0	110	43
	Lightest Cool Pink	461	100	39	0	0	75	29
X	Light Cool Pink	465	100	39	0	0	100	39
	Dark Cool Pink	467	100	39	0	0	125	49
	Bright Magenta	469	100	39	0	0	170	67
	Light Cool Magenta	473	25	10	0	0	165	65
X	Med. Cool Magenta	471	75	29	0	0	165	65
	Dark Magenta	481	0	0	0	0	235	92
	Magenta	483	0	0	0	0	200	78
	Dark Pink	485	0	0	0	0	165	65
	Pink	486	0	0	0	0	135	53
	Dark Warm Pink	487	0	0	85	33	175	69
X	Warm Pink	488	0	0	85	33	150	59
	Light Warm Pink	489	0	0	85	33	110	43
X	Black	500	255	100	255	100	255	100

2.1.4 Beam

The *beam* function controls the column of light exiting the lens of the luminaire. This column of light is made up of thousands of individual light rays. The outer part of this column is the beam edge. In the case of the **AR50** wash luminaire, controlling the beam is accomplished with a diffuser that blends the light rays thereby softening the light and the beam edge. This will cause the column of light to spread out slightly creating a somewhat broader, smoother beam. The diffuser uses a radial filter mechanism with stippled diffusing panels installed instead of color filters. When chosen as an order option, the diffuser is generally located in the front of the luminaire between the color changing mechanisms and the front lens.

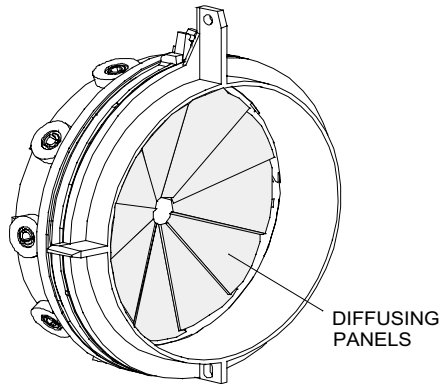

2.1.5 Timing

The *timing* function controls the time required to execute a cue and is the fifth and final function to be described. There are two types of *timing*: *Transition* time and *Delay* time.

Transition time is the time allowed for a function to complete its operation. For example: One preset may position a luminaire to shine on a wall and the next preset may require the luminaire to pan over to illuminate a speaker's podium. The time allowed for the luminaire to move from the wall to the podium is the *transition* time. *Transition* times can be individually set for each of the other four functions (*intensity*, *focus*, *color*, and *beam*). *Transition* times can range from one second to a maximum of 30 minutes and 50 seconds utilizing one second intervals up to 255 seconds (4 min. 15 sec.) and ten second intervals above 255. *Timing* can be used to synchronize the motions of several luminaires so that they all arrive at their new intensity, focus, color, and beam at the same time even though they each may have to pan and tilt through different distances.

Delay time is a wait state representing the interval between the time the preset is executed and the time the designated functions begin their transitions. A single delay time can be assigned to one or more functions.

For example: It may be desirable for one or more luminaires washing the walls of a dining room with soft blue light to move their beams slowly to a speaker's podium and then to go white upon arrival drawing obvious attention to the speaker. In this instance the lighting designer might choose to set the transition time of the focus to 20 seconds and the transition time of the color to 0 seconds. This would allow the luminaires to make a gradual movement toward the podium with a near instantaneous change from blue to white. To prevent the light from changing from blue to white at the beginning of the pan movement, the designer would specify that a delay time of 19 or 20 seconds be provided and affect only the color.

The features are defined and combined using a PC and result in a specific look known as a "lighting state" or preset.

Programmed lighting states may be stored in the Master Control Processor (MCP) or PC. Commands are transmitted from the controller instructing the addressed luminaires to initiate specific "presets" or sequences of presets. Each luminaire evaluates the command to determine if it has been addressed and interprets the instructions accordingly. Commands may originate from PC, Master Control Processor, or Remote Stations

2.1.6 Pan / Tilt Positioning

The on-board processor controls individual pan and tilt motors that direct the luminaire to the desired positions within the transition time specified by the preset or manual control.

2.1.7 Color Changing

Dichroic filters are used in the construction of the color changing mechanisms. The filters block some wavelengths of light and allow others to pass through the filter creating the colored beam. With dichroic filters, the angle at which the light passes through the filter determines which colors within a given range will be blocked and which will pass. A motor is attached to each mechanism allowing it to pivot its filters as directed by the microprocessor and vary the angle of the filters in the light path. The series of three color mechanisms, used individually or in combination, allow the colors to be selected from the entire color spectrum with complete control and repeatability.

Diffusion and/or douser panels are optional assemblies which provide dynamic control of the beam distribution or full-field intensity dimming.

An AR50 luminaire with color changing capability can have a diffuser or douser, or neither, but cannot have both.

2.1.8 Light Distribution

The standard lens kit supplied with each luminaire has three lenses including a very narrow spot, narrow spot, and medium flood lens.

2.2 Configurations

Two types of configurations are discussed herein for the **AR50** luminaires: System Configurations defining interconnection of the luminaires with acceptable control systems and individual Unit Configurations identifying the ordering variations of the luminaires.

2.2.1 System Configuration

The **ETC-IRIDEON** lighting system consists of **IRIDEON** interior luminaires and the **Composer** control system. The control system may be supported by only a PC; a PC and Master Control Processor; PC, Master Control Processor and Remote stations; or DMX Interpreter with DMX512 input.

2.2.1.1 Composer Lite Control System

In the PC only control system, 31 **IRIDEON** luminaires can be supported on a single data run with single zone control utilizing the **IRIDEON** data protocol for luminaire operation. RS232 to RS485 conversion is required for PC to connect directly to luminaires. This may be accomplished by either an RS485 communications card added to the PC or an RS232 to RS485 conversion module.

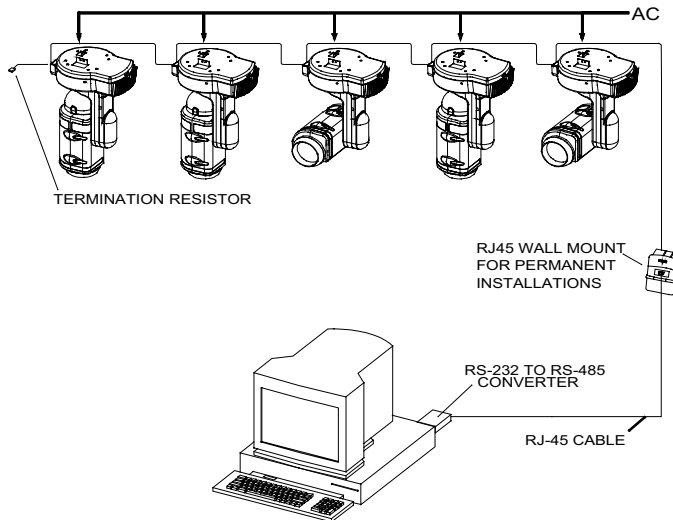

2.2.1.2 MCP Control System

A control system featuring a Master Control Processor is able to support 62 **IRIDEON** luminaires on 2 data runs utilizing the **IRIDEON** data protocol for luminaire operation. Optional remote stations provide the added flexibility of global and zone specific recall buttons, dual button entry stations, and 8 event closure/join stations.

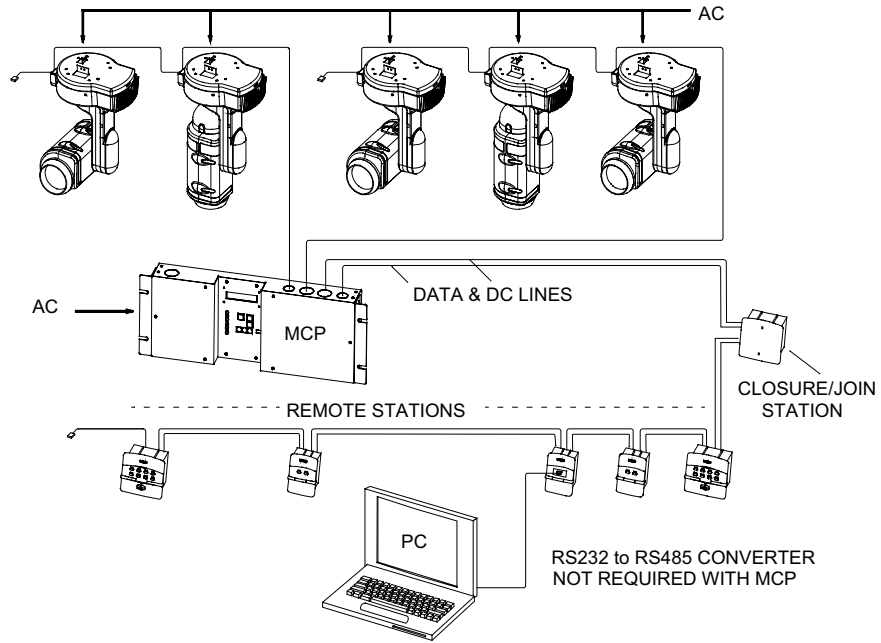

2.2.1.3 DMX Interpreter Control System

The DMX Interpreter receives DMX512 data and converts it to the **IRIDEON** data protocol for luminaire operation. Up to 31 **IRIDEON** luminaires are supported on each of 2 data runs for a total of 62 luminaires.

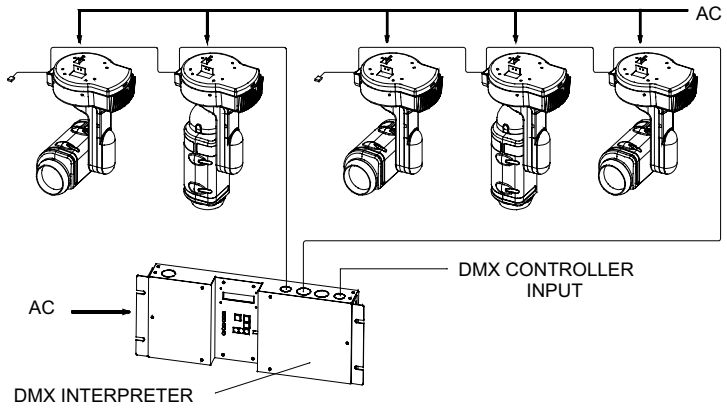

2.2.2 Unit Configuration

The **IRIDEON AR50** luminaire is factory configurable to satisfy user requirements. The luminaire supplied has been assembled to customer specifications identified in the selected catalog number. A description and example of part number construction follows:

EXAMPLE

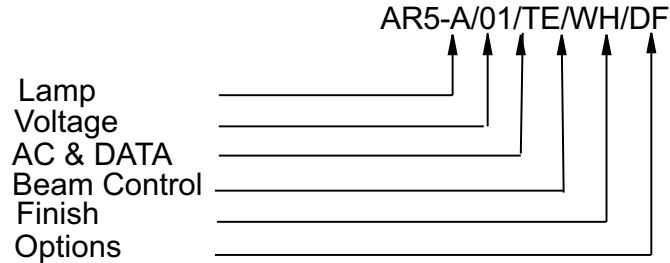

DESCRIPTION

Lamp: A = DL-50W (50watt) arc source 3000 hr life
Voltage: 01 = 100 - 240 VAC. 50/60 Hz

AC & Data Connection: TE = Top Entry
CO = Connector, (IEC, 5-PIN XLR)

Finish: WH = White
BL = Black
(Consult factory for other finishes)

Options: DF = Diffuser
DS = Douser
NC = No color change
ND = No color change with Douser and Diffuser

In the above example, the specified luminaire has the following characteristics: 50watt bulb / 100-240 VAC input voltage / Top Entry for AC and Data wiring connection / External Luminaire color is white / Diffuser beam control bulkhead in addition to the standard color changing bulkheads.

Note: Color changing bulkheads are automatically included as standard items unless options “NC” or “ND” are selected.

2.2.2.1 AC and Data Connection

AC and Data connect options selected at time of order placement reflects the chosen method of wiring connection into and out of the luminaire and determines which I/O panel is supplied. The surface to which each luminaire is to be mounted (concrete, wood, metal rafters, etc) should be considered prior to order placement to ensure luminaire I/O panel supports method of wire routing.

When the *Connector* option is selected for AC and Data Connection, an I/O panel is supplied in the upper enclosure of the luminaire with one IEC 3-prong AC connector and two 5-pin XLR connectors for Data In and Data Thru . This provides for portable mounting of luminaire. Two C-clamps are provided with this option to support the portable mount (optional rubber mounting feet are also available).

The *Top Entry* option of AC and Data connection is intended for applications when the luminaire is to be mounted to one junction box with wire connections within that box. When this option is selected, the I/O panel is supplied with a power switch only.

Note: Note:Use ETC supplied J-box for Top Entry mounting (Part #: 7092A1001).

2.2.2.2 Beam Control

Beam control is available via time variable diffusion and/or dousing of the light beam as it exits the luminaire. The diffusion mechanism provides precise and dynamic control of beam distribution. The douser mechanism provides full-field dimming of the beam intensity.

(This page intentionally blank)

Chapter 3 - Installation

This chapter contains the following sections:

- 3.1 Site Preparation
- 3.2 Input Power and Control Cabling
- 3.3 Luminaire Installation Procedure
- 3.4 Fixture Address
- 3.5 Power Up

3.1 Site Preparation

The **IRIDEON AR50** Interior Wash Luminaire may be mounted in either of two orientations (ceiling, or floor). The installation location must provide an indoor non-condensing, low humidity environment. The luminaire should be securely mounted to a surface capable of supporting 9 lbs (4.08 kg). Firmly securing the luminaire in place will prevent “wobble” of the fixture during pan and tilt movements.

See illustration below for operating clearances.

Note: Mount the base on a horizontal surface only. Failure to do so will shorten the fixture life, and may void warranty.

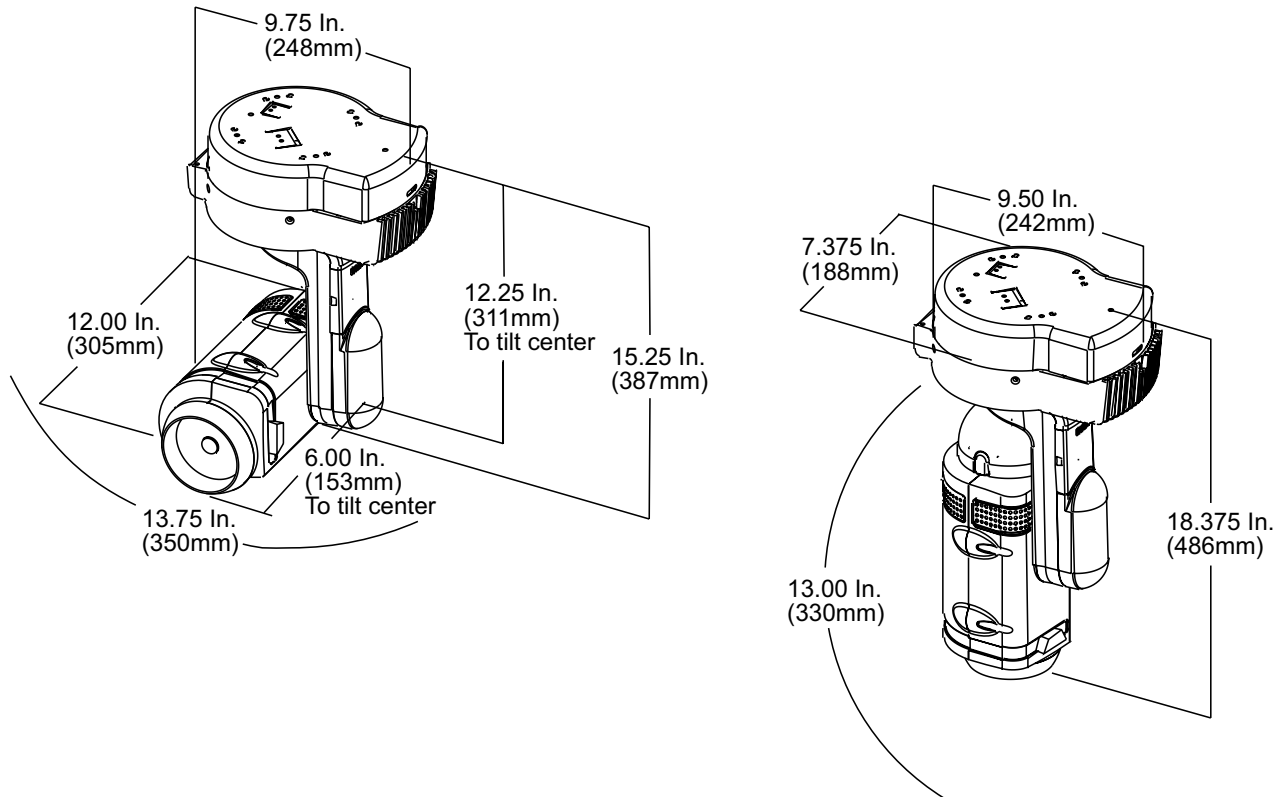

3.2 Input Power and Control Cabling

Note: The installation contractor is responsible for compliance with local electrical codes.

Note: Data and AC power are to be routed through separate conduit.

Note: Irideon supplied J-Box contains wiring barrier to separate AC from Data.

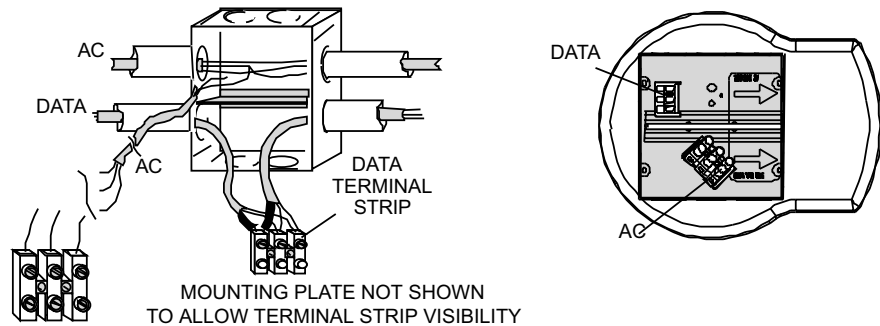

View of Irideon Junction Box with wiring barrier

3.2.1 AC Power Input

AR50 luminaire power requirements at sample voltages are listed below.

AR50 with 50 watt lamp:

100V @ 0.85A

240V @ 0.380A

120V @ 0.7A

AC wiring may use 18 - 10 AWG service to junction box. Connect as follows:

Wire	Connection
BLACK *(BROWN)	AC LINE
WHITE *(BLUE)	AC NEUTRAL
GREEN or bare *(GRN/YEL)	GROUND

* International (Harmonized) Standard

3.2.2 Data Wiring

Type: Belden 9729 (or equivalent), twisted shielded part, 24AWG

Capacity between conductors: 12.5 pf/ft. (49 pf/m)

Nominal Impedance: 100Ω

If data cable is installed in a daisy-chain (feed-thru) configuration, install a 100Ω 1/4 watt termination resistor (provided) at end-of-line between positive data line and negative data line. Drain wire should be grounded.

3.3 Luminaire Installation Procedure

3.3.1 Unpacking

Remove the luminaire from its packing carton. Remove lens set from packing carton. Save packing materials in event luminaire requires future shipment.

A lens set is included with each luminaire to provide a range of beam sizes/patterns. Included in the set are:

- Very Narrow Spot (7.5° beam angle)
- Narrow Spot (15° beam angle)
- Medium Flood (30° beam angle)

The luminaire is shipped with the Narrow Spot lens installed.

To change lenses:

- Step 1. Grasp luminaire front ring and turn counter-clockwise to remove from luminaire.
- Step 2. Holding front ring with both hands, apply thumb pressure to front side of lens freeing lens from front ring retaining notches.
- Step 3. Place replacement lens against back side of front ring. Position concentric rings of lens toward rear (facing toward the light source) and black lens plug facing forward.
- Step 4. Holding front ring with both hands, apply thumb pressure to lens forcing it into front ring retaining notches.
- Step 5. Install front ring lens assembly on luminaire.

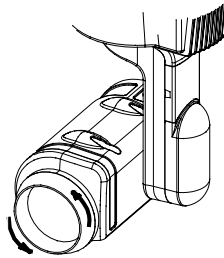

Unscrew front ring from luminaire.

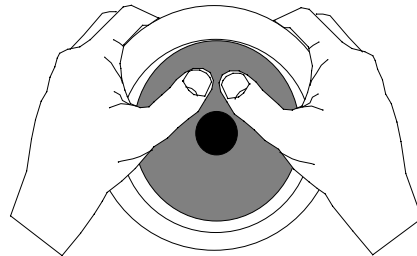

With thumb pressure, "Pop" the lens out of the front ring.

Replacement of Front Lens

3.3.2 Mounting

Note: It is recommended that luminaires be mounted with consistent orientation. Failure to do so may result in complicated programming instructions associated with directing movement of multiple luminaires simultaneously.

The luminaire provides for 360° pan rotation, however, a pan stop is located on the underside of the upper enclosure preventing the yoke from continuous rotation. When the luminaire anticipates reaching the pan stop during the execution of its next move, it will move to its next location by rotating through the reverse direction.

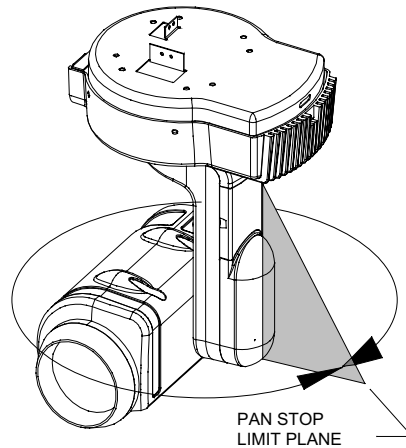

Pan Stop Limits

Consequently, if two luminaires were executing the same instruction but were oriented differently, they might take different paths to accomplish the same instruction.

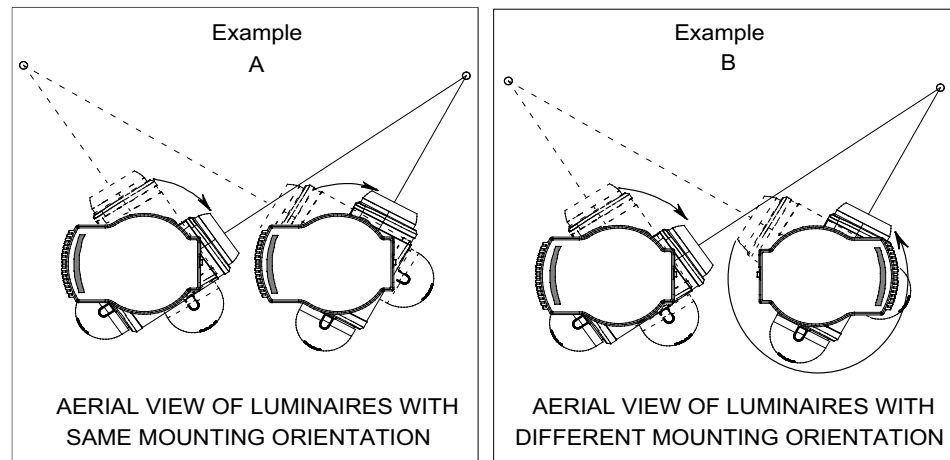

Example of Instruction Execution Path

Most mounting requirements can be satisfied by the universal mounting plates provided with the **AR50** luminaire. These mounting plates are equipped with screw holes compatible with the Irideon supplied J-Box with wiring barrier.

Portable mounting is accomplished by either C-clamps or rubber feet. These can be easily attached to the mounting plate to support ceiling or table-top use.

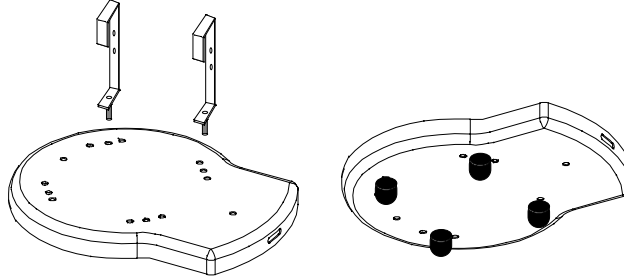

Note: If a specific mounting requirement is not supported by the universal mounting plates, contact the ETC, Inc. factory for a customized mounting plate.

The mounting plate must be securely attached to the mounting surface to ensure proper support for the luminaire and any torque generated by it.

AC and Data connection requirements specified at time of order placement affect the method of installation and wiring hookup. Wiring connection is accomplished by one of the following two methods:

Top Entry: Direct attachment of wiring to terminal strips on the mounting plate.

Connector: Plug-in connectors to the I/O panel of the upper enclosure.

Top entry option

When the luminaire is mounted to a junction box as in the Top Entry method of installation, the Irideon supplied junction box is to be used above the upper enclosure (Part Number: 7092A1001).

To install luminaire with top entry wiring option:

1. Attach input AC and Data wiring to top portion of terminal blocks secured to mounting plate.
2. Align mounting plate holes with junction box and firmly attach with appropriate screws. Failure to attach mounting plate firmly may result in “wobble” of luminaire during pan and tilt operation.

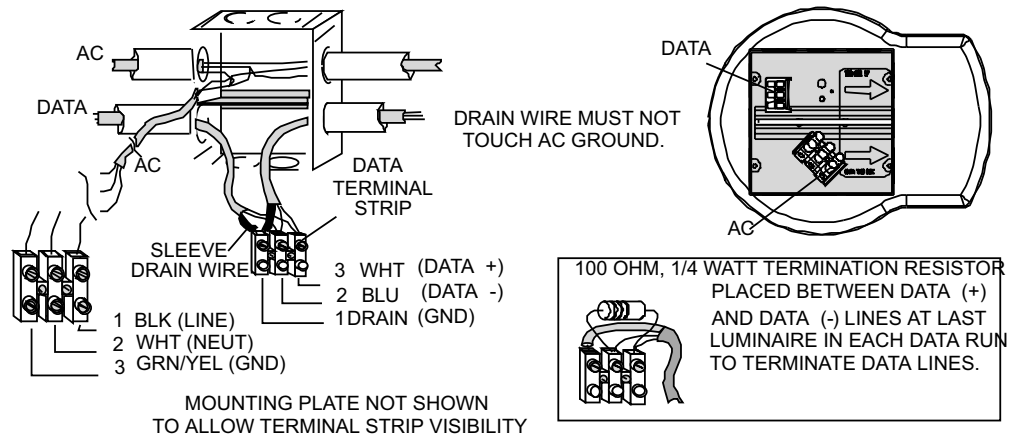

Mounting Plate Hook up for Top Entry Option

3. Extend J-hook on upper enclosure and attach to slot on mounting plate. This will suspend luminaire without placing physical strain on electrical wiring while connecting to terminal block.

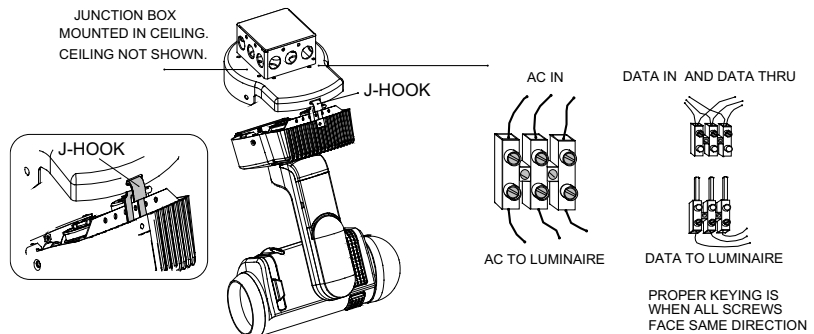

4. Connect AC to terminal block. Connect Data male and female terminal block halves.
5. Lift Luminaire into position over mounting plate and secure in place with four 8-32 x 1/2” PFZ screws provided.

Connector option

When the cabling is attached to the luminaire by connectors, the mounting plate can be secured directly to the mounting surface. Failure to attach the mounting plate firmly may result in “wobble” of luminaire during the pan and tilt operation. The luminaire’s upper enclosure attaches directly to the mounting plate with no internal wiring considerations. Extend the J-hook on the upper enclosure and slide through slot on mounting plate. This will provide added support for the luminaire during connection and future disconnection of the luminaire. Lift the luminaire into position over the mounting plate and secure in place with the four 8-32 x 1/2” PFZ screws provided.

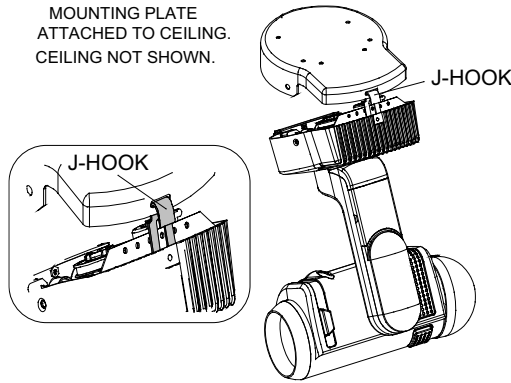

If a luminaire must be temporarily removed from a data run, unplug the Data In and Data Thru cables from the unit and join the male and female connectors together to allow continued data flow to the remaining luminaires.

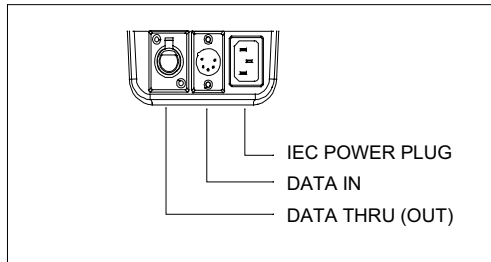

BELDEN 9729 PIN/WIRE CODE TO XLR CONNECTORS				
<p>DATA THRU CABLE PINOUT</p> <p>MALE CONNECTOR</p>	<p>PIN 1 DRAIN</p>	<p>PIN 2 BLUE DATA -</p>	<p>PIN 3 WHITE DATA +</p>	<p>DATA IN CABLE PINOUT</p> <p>FEMALE CONNECTOR</p>

Connector Input Detail

120 OHM, 1/4 WATT TERMINATION RESISTOR MOUNTED IN 5-PIN MALE XLR CONNECTOR. CONNECTING DATA + AND DATA - LINES TOGETHER (PINS 2 & 3) AT LAST LUMINAIRE IN EACH DATA RUN TO TERMINATE DATA LINES.

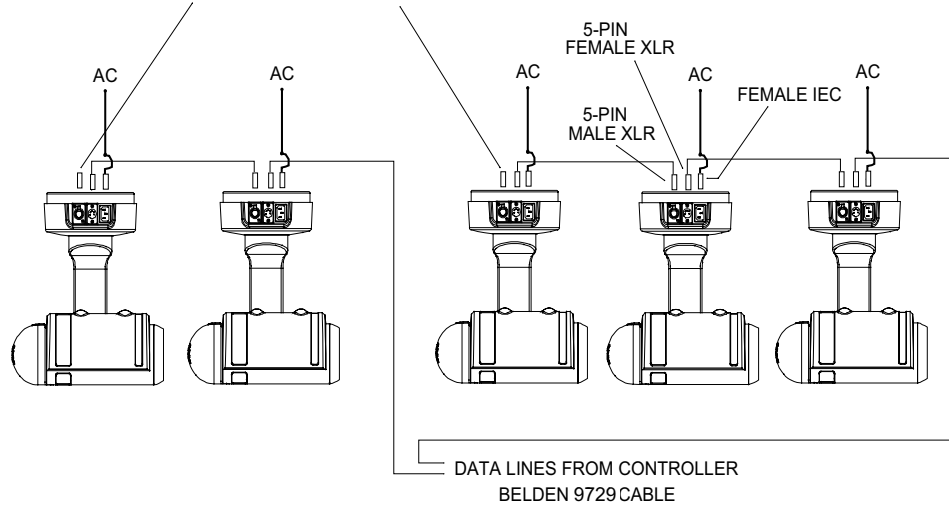

Example of Connectorized Hookup Option

3.4 Fixture Address

The luminaire address is set by two rotary switches located behind the access door in the yoke arm of the fixture (See illustration below). The switch furthest from the door's hinge is the ten's position and the switch closest to the door's hinge is the one's position (For example, in the illustration below a setting of 26 would require the switch on the left to be set to "2" and the switch on the right to be set to "6".) Each luminaire in a system must be set to the appropriate address in order to receive the proper data that controls that individual luminaire. Luminaire address selection typically results from the overall plans of the lighting designer. Specific addresses for each fixture should be furnished by that designer.

Fixture address "00" (that is, both rotary switches set to "0") is the luminaire's self test address. Internal commands direct the luminaire to perform a predetermined self test routine when switches are set in this position and power is applied. No external data commands are required for this test.

Note: After the self test has been performed, return address switches to their designated fixture address or command data will not be recognized by the luminaire (See section 4.1 for additional self test information).

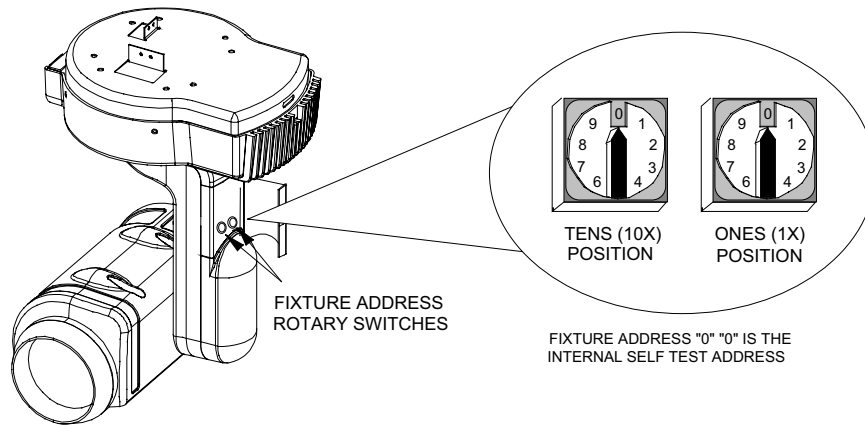

Fixture Address Rotary Switch Location

3.5 Power Up

When power is applied, the arc bulb will “strike” or ignite and the luminaire will illuminate. The luminaire will immediately begin a calibration sequence that steps it through full pan and tilt movements. The internal color changing mechanisms will also be exercised to fully open and fully closed positions. After calibration the luminaire will come to its “home” position which positions the pan movement at mid-rotation and the head positioned parallel to the yoke with the light beam aimed away from the luminaire upper enclosure. All color changing mechanisms, douser, and diffuser will be in full open position so that light is white.

(This page intentionally blank)

Chapter 4 - Test

This chapter contains the following sections:

4.1 Self Test

4.2 System Test

(This page intentionally blank)

4.1 Self Test

Internal diagnostic self tests are provided with the luminaire to exercise color and movement mechanisms. Set fixture address to "00" to initiate self tests.

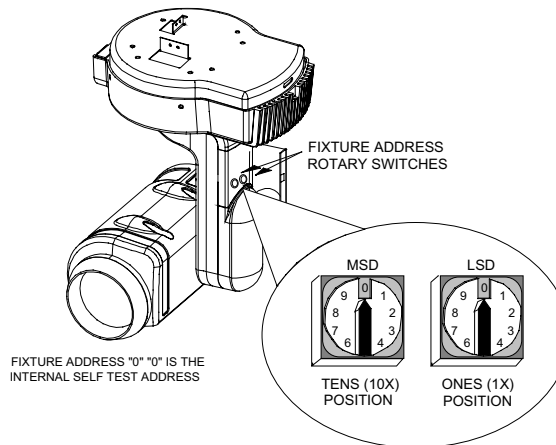

In self test, the Most Significant Digit (**MSD**) of the fixture address rotary switches regulates the rate at which the mechanisms move. Use the table below to determine test rates.

Note: For pan and tilt movements, speeds below five seconds are not achievable to test full movement extremes. Observable speed differences for pan and tilt testing should be limited to settings between 5 and 9.

MSD Setting	Rate (time between travel extremes)	MSD Setting	Rate (time between travel extremes)
0	maximum speed	5	5 seconds
1	1 second *	6	6 seconds
2	2 seconds *	7	7 seconds
3	3 seconds *	8	8 seconds
4	4 seconds *	9	9 seconds

* These times do not apply to pan and tilt movements. With these time settings luminaire will operate at max pan and tilt speed (approximately 5 second rate from one extreme to the other).

In self test, the Least Significant Digit (**LSD**) of the fixture address rotary switches selects the mechanisms to be tested. Use the table below to determine selected mechanisms.

LSD Setting	Test Description
0	Cycles each mechanism [blue, amber, magenta, dimmer (douser) or diffuser, pan, then tilt] back and forth one at a time then all mechanisms at once.
1	Cycles blue filter mechanism open and closed
2	Cycles amber filter mechanism open and closed
3	Cycles magenta filter mechanism open and closed
4	Cycles dimmer (douser) or diffuser, whichever is installed, if any open and closed
5	Cycles pan to limit extremes
6	Cycles tilt to limit extremes
7	Cycles each filter (blue, amber, magenta, then dimmer) open and closed
8	Cycles pan then tilt to limit extremes
9	Cycles all mechanisms at once

To perform self test:

1. Set both fixture address switches (MSD and LSD) to “0”. Within five seconds the Green LED will begin to blink at a rate of on for two seconds and off for two seconds.
2. Wait for approximately ten seconds. Within ten seconds the Green LED will begin to flash at a rate of two flashes per second. At this point the luminaire will begin self test, as detailed in the above tables, for the MSD “0” and LSD “0” condition. Once self test has begun, the MSD and LSD switches may be moved to other positions to test for proper operation of desired mechanisms.

When all desired tests have completed perform Step 3.

3. Return switches to the “00” address. Wait for slow flash of Green LED to indicate luminaire has returned to normal operation. When LED begins to flash at the slower speed, return address switches to original fixture address within ten seconds. Failure to begin setting address switches within ten seconds will return luminaire to test mode.

Note: To exit self test mode, address switches must be moved to some test position other than “00” and then returned to “00”. If test is performed only at “00” LED will not resume slow flash to allow exit from testing.

4.2 System Test

Refer to **Composer** or **Composer Lite** operating system documentation for system testing.

(This page intentionally blank)

Chapter 5 - Troubleshooting

Note: If it becomes necessary or desirable to return a subassembly or the luminaire to an authorized service center, a Return Material Authorization (RMA) must be obtained prior to shipment. Items will not be accepted without an RMA number.

AC power is required to strike (or ignite) and maintain illumination of the bulb. AC power is also required by the Low Voltage Power Supply to create +5 volt DC for operation of PCBs and +15 volt DC to drive motors controlling movement and color changing mechanisms. The following troubleshooting steps are designed to aid the user in symptom diagnostics.

No Response to Movement Commands and Lamp not Lit.

Movement is controlled by DC motors. Lamp is lit by AC power. This combination of no movement and unlit lamp indicates no power is going to the luminaire.

1. Verify circuit breaker is on (Are other items on same circuit working properly?). Turn power off and back on. If luminaire has connectors on I/O bracket of upper enclosure, ensure power cord is properly seated.
 2. Open yoke arm access door and observe yellow LED. Yellow LED “on” indicates DC power is present. AC power must be present for DC power to be present.
 3. If yellow LED is not on, DC power is not present but AC power may or may not be present. To check AC power, remove power to luminaire for at least 20 seconds. Restore power and listen for “clicking” sound from head of luminaire (if sound is present, bulb is trying to strike indicating presence of AC power). Striking will time out after 20 seconds.
 4. If AC power is present but yellow LED is not on, replace the Low Voltage Power Supply in the upper enclosure. If bulb tried to strike but did not ignite, replace bulb.
-

CAUTION: Do not touch glass portion of bulb.

If bulb did not attempt to strike (i.e. no clicking sound) and yellow LED is off, have qualified electrician check power to luminaire.

If yellow LED is on, perform self test described in Chapter 4. Observe green LED during self test.

If no movement during self test and green LED does not flash, replace CPU PCB in yoke arm.

If no movement during self test and green LED flashes, replace the Low Voltage Power Supply in upper enclosure.

If luminaire responds to self test, check data wiring from system controller and initiate self test from system controller.

No Response to Movement Commands but Lamp is Lit.

Illuminated lamp indicates AC power is present in luminaire.

Open Yoke Arm access door and observe yellow LED.

If yellow LED is not on, replace Low Voltage Power Supply in the upper enclosure.

If yellow LED is on, perform self test described in Chapter 4. Observe green LED during self test.

If no movement during self test and green LED is not flashing, replace CPU PCB in yoke arm.

If no movement during self test and green LED is flashing, replace Low Voltage Power Supply in upper enclosure.

If luminaire responds to self test, check data wiring and initiate self test from system controller.

Luminaire responds to movement commands but lamp will not Light.

Remove power to luminaire for at least 20 seconds. Restore power and listen for “buzzing” sound from head of luminaire. “buzzing” sound indicates bulb is trying to strike. Striking will time out after 2 seconds.

If “clicking” sound is present but bulb will not ignite, replace bulb.

CAUTION: Do not touch glass portion of bulb.

If no “buzzing” sound is present, either the Low Voltage Power Supply or the Ballast may be bad. Replace one at a time starting with the Ballast or call **ETC** Tech Support.

Chapter 6 - Maintenance

WARNING: Potentially hazardous voltages exist and LAMP may be extremely hot.

This chapter deals with the removal and installation of user replaceable items and contains the following sections:

6.1 LAMP Replacement

6.2 Replacement of CPU PCB

6.3 Replacement of Low Voltage Power Supply, Ballast and/or Igniter.

6.1 Lamp Replacement

WARNING: Safety lock switches in the luminaire head are designed to remove high voltage from the lamp when the head's door is opened. Other voltages will remain present, however. Power to the luminaire should be turned off prior to maintenance being performed.

The base of the arc lamp is of a bayonet type. It is inserted by aligning raised knobs or pins on the lamp base with notches on the lamp socket. The lamp is held in place by sliding a large metal clip across the reflector mount opening, engaging the lamp. Removal is the reverse of this procedure.

To remove the lamp:

1. Open door at rear of luminaire head.
 2. Twist lamp socket counter clockwise and remove from lamp.
 3. Grasp large metal clip and pull to side, releasing lamp from reflector mount.
-

Note: The clip is not intended to pull completely free from the reflector mount.

4. Remove lamp.
 5. Insert new lamp by aligning notch on lamp base with keyway in reflector mount. Reverse above procedure to secure lamp and socket in luminaire reflector mount.
-

CAUTION: Do not touch the glass portion of the lamp with bare hands. This will leave skin oils, which will damage the lamp when it reaches full operating temperature.

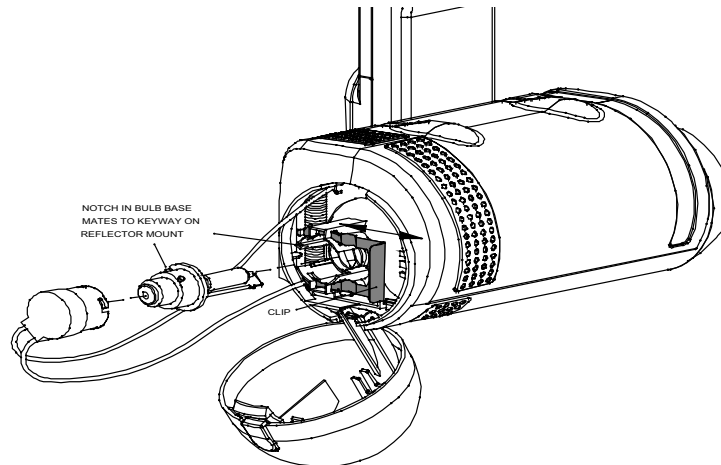

6.2 Replacement of CPU PCB

WARNING: Remove power to luminaire at main breaker prior to performing maintenance.

The Central Processing Unit (CPU) Printed Circuit Board housed in the yoke arm contains the luminaire's microprocessor which converts communication control data into actual motor instruction.

To remove and replace the CPU PCB:

1. Open the Yoke Cover Door.
2. Using a phillips screwdriver, remove exposed 6-32 X 1/4" ph PH MS Zinc screw located next to yellow and green LEDs.
3. Using a small slot screwdriver, pry Yoke Cover loose from Yoke Arm. Begin at rounded end closest to luminaire head.
4. Observe five connectors at one end of CPU PCB. Each cable corresponds to a specific filter actuator or motor. It is extremely important that each cable be reconnected to its proper receptacle after board replacement to ensure correct operation. It is possible that one or more connectors may be unused based on chosen capabilities of your luminaire. Before disconnecting cables ensure that each is numbered and/or color coded in a way that corresponds to its proper connector receptacle.

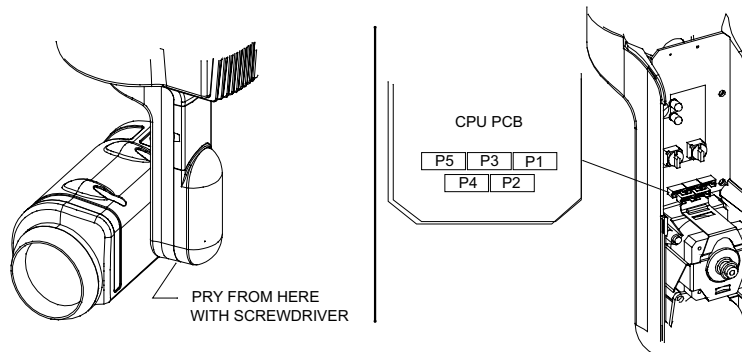

Connector / Function Table

Conn. / Heatshrink	With color filters only	Color with Douser or Diffuser	Douser and Diffuser only
P1 / Blue	Blue Filter	Blue Filter	
P2 / Yellow	Amber Filter	Amber Filter	
P3 / Red	Magenta Filter	Magenta Filter	Diffuser
P4 / Black		Douser or Diffuser	Douser
P5 / none	Tilt Motor	Tilt Motor	Tilt Motor

5. Unplug cables from CPU PCB.
6. Using a Phillips screwdriver remove three screws from PCB.
7. Remove three additional cables located on the back side of PCB. They are:
 - Pan motor P6
 - DC power input P8
 - Data input P7.

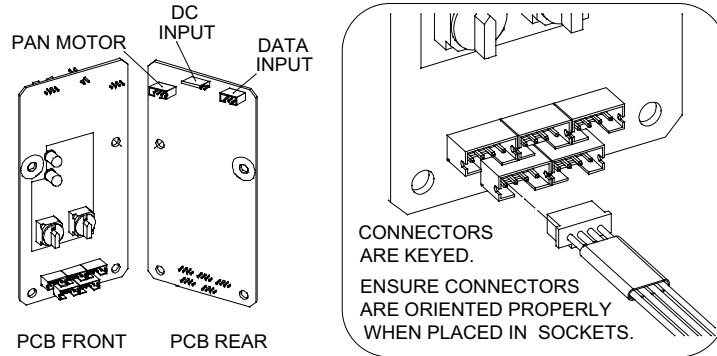

8. Remove and replace CPU PCB.
9. Replace cables to P6, P7, and P8 on backside of PCB.
10. Thread three 5/16" #6 Type F screws through PCB and into Yoke Arm.
11. Reconnect cables on front side of PCB. Ensure each cable is replaced in its original location.
12. Replace Yoke Cover.
13. Thread 3/8" #6 Type F screw through Yoke Cover and PCB and into Yoke Arm.

Note: In addition to securing the Yoke Cover in place, the 3/8" #6 screw is required to ensure proper grounding of the circuitry in the CPU PCB.

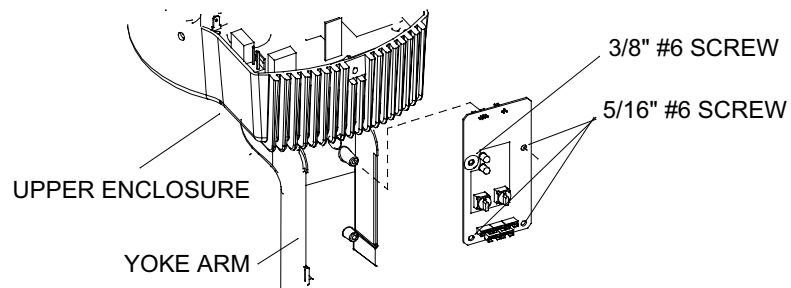

6.3 Upper Enclosure Replacement Procedures

WARNING: Remove power to luminaire at main breaker prior to performing maintenance.

6.3.1 Removal and Replacement of Ballast and Low Voltage Power Supply

Tools: Screwdriver: phillips

Parts: New Ballast

New Low Voltage Power Supply

1. On the Ballast, locate and unplug the Neutral (white), Hot (black) and Ground connectors as shown in the drawing on the following pages.
 2. Unplug the 2-pin Igniter connector, the 2-pin Fan connector, and if applicable, the 4-pin Remote Turn-on connector.
 3. Remove 4 screws and set aside Ballast.
 4. Remove 3 screws on Base plate and set aside.
-

Note: The connector on the third screw is the Ground wire.

5. Remove 4 screws from the Low Voltage Power Supply.
 6. Remove Nomex Insulator for Power Supply.
 7. Unplug the 2-pin AC Power Connector.
 8. Unplug the 8-pin Logic Power Harness.
 9. Replace defective part.
 10. Reconnect the 8-pin Logic Power Harness and the 2-pin AC Power Connector to the Low Voltage Power Supply.
 11. Replace 4 mounting screws to secure the Power Supply.
 12. Replace 3 screws to secure the Base Plate.
-

Note: Be sure to replace Ground connector on the third screw.

13. Mount Ballast using 4 screws.
-

Note: Orient Ballast with label facing to the inside of the base.

14. Reconnect the Neutral (white), Hot (black) and Ground connectors onto the AC input power connector pins.
15. Reconnect the 2-pin Igniter connector, the 2-pin Fan connector, and the 4-pin Remote Turn-on connector.

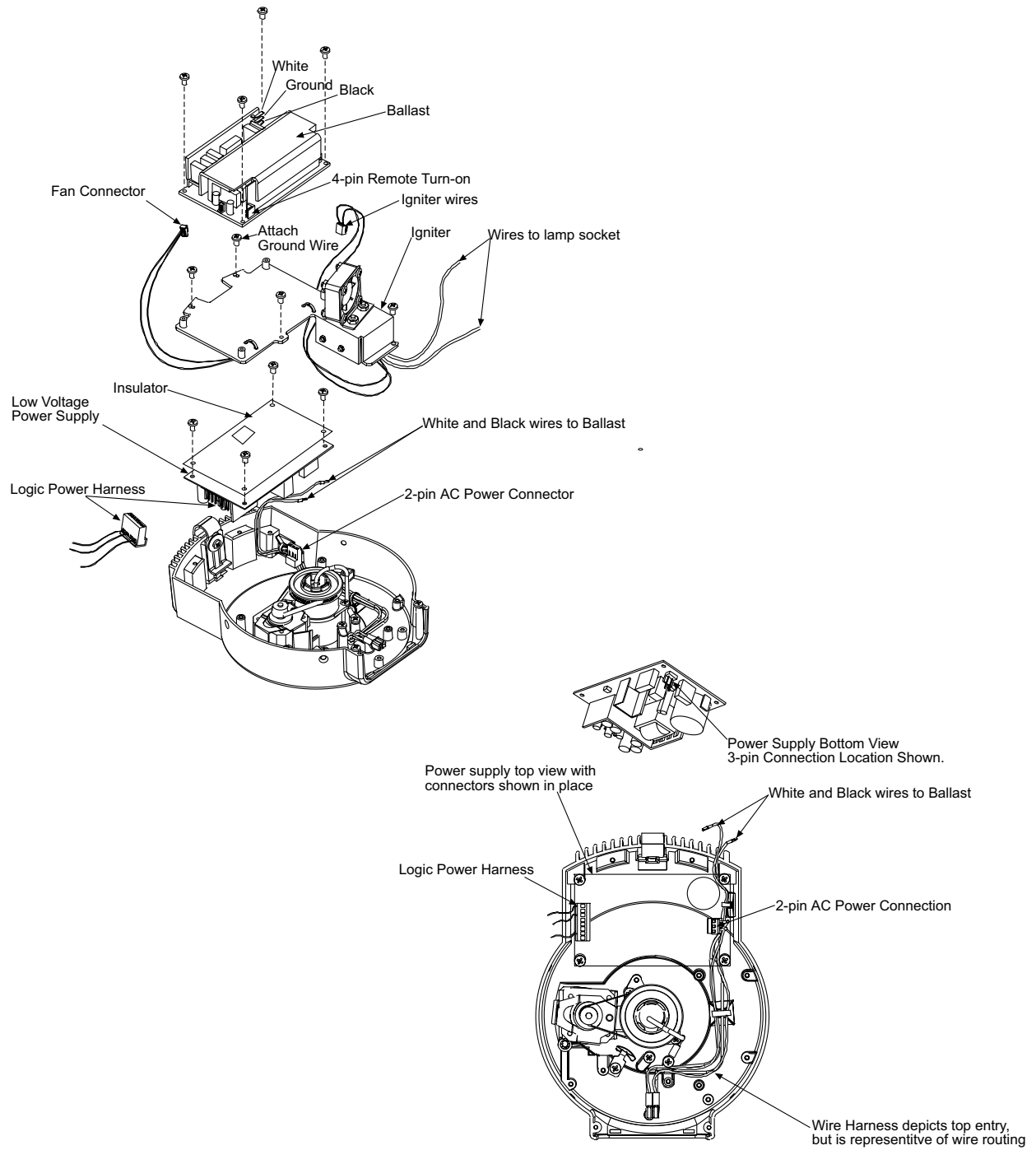

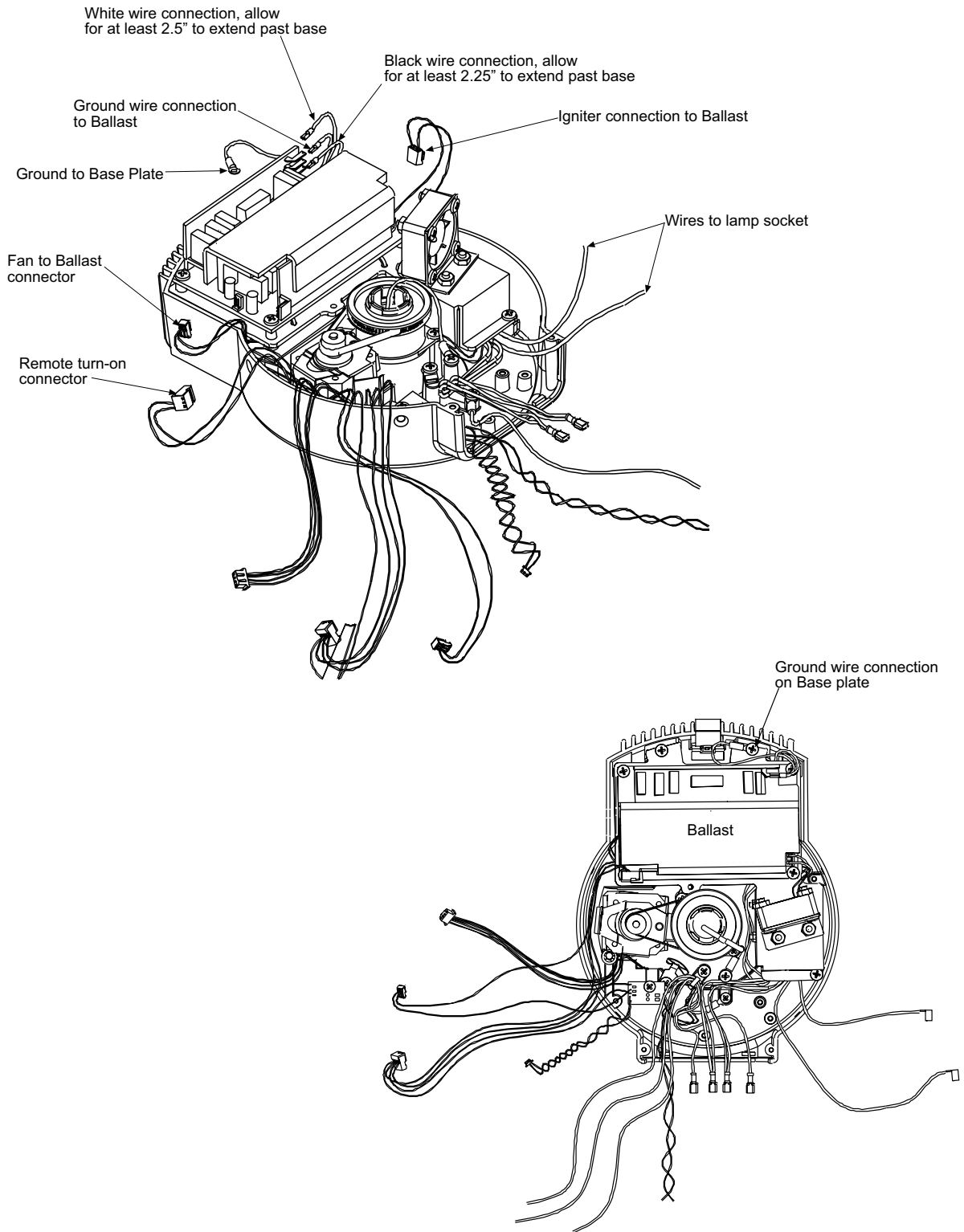

(This page intentionally blank)

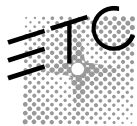

Americas • 3030 Laura Lane Middleton, WI 53562 • Tel: (+1) 608.831.4116 • Fax: (+1) 608.836.1736 • Toll free: 800.688.4116 • Toll free fax: 800.555.8912
Europe • 5 Victoria Industrial Estate, Victoria Road, London W3 6UU • Tel: +44 (0)20 8896 1000 • Fax: +44 (0)20 8896 2000
Asia • Room 605-606, Tower III Enterprise Square • 9 Sheung Yuet Road, Kowloon Bay • Kowloon, Hong Kong • Tel: (+852) 2799 1220 • Fax: (+852) 2799 9325
International • 3030 Laura Lane Middleton, WI 53562 • Tel: (+1) 608.831.4116 • Fax: (+1) 608.836.1736 • Toll free: 800.688.4116 • Toll free fax: 800.555.8912
Web: www.etcconnect.com • **Email:** mail@etcconnect.com

Copyright © 2000 Electronic Theatre Controls, Inc., All Rights Reserved. All product information and specifications subject to change. 7092M1007 Rev. A

